



Specification For Approval

Customer : _____
Description : _____ EC FAN _____
Customer Part No. : _____ Rev : _____
Delta Model No. : _____ GTW063EUD19R _____ Rev : 02
Safety Model No. : _____ GTW063EUD19 _____
Sample Issue No. : _____
Sample Issue Date : _____ 07/01/2019 _____

Please send one copy of this specification back after
you signed approval for production pre-arrangement

Approved by : _____

Date : _____

Delta Electronics, Inc.
No.252, Shangying Road, Guishan Industrial Zone,
Taoyuan City, 33341, Taiwan

TEL : +886-3-359-1968
FAX : +886-3-359-1991

Electronically Commutated (EC) Fan

Axial Fan

805 x 805 x 220 mm



Delta Electronics, Inc.
 No.252, Shangying Road, Guishan
 Industrial Zone, Taoyuan City,
 33341, Taiwan
 TEL: +886-3-359-1968
 FAX: +886-3-359-1991
www.deltaww.com



Technical features

Input Side	
Nominal Voltage	1~ 230Vac 50/60Hz
Input Source	1~ 200Vac - 277Vac
Power @ Free air	500W
Power @ Max. load	800 W
Output Side	
Speed (RPM)	1100
Qmax. (CMH / CFM)	12270 / 7222
Pmax. (Pa / inAq)	160 / 0.64
Noise (dB-A) @ Qmax	71.5
Functions	
Active power factor correction	
Control input 0-10VDC / PWM / 4-20mA.	
Output +10VDC ($\pm 10\%$), max. 10mA.	
Control voltage output: 0-10VDC.	
RS485 control bus (MODBUS (V1.0) RTU/ 8N1)	
Alarm relay, Locked rotor protection, Soft start.	
Speed telling, frequency generator signal.	
Voltage / Current monitoring.	

Physical	
Rotation Direction	CCW, seen on rotor
Material (Impeller / Frame)	Plastic / Steel
Bearing system	Ball bearings
Weight (kg)	27
Electrical leads	Via terminal block
Environmental	
Operating temperature range	-25 ~ +60 °C
Storage temperature range	-40 ~ +70 °C
Safety	
Safety	UL ,CUL,TUV
IP Level	IP54
EMC	EN61000-6-2/4 , EN61000-3-2/3
Protection class	I
Insulation class	F
Leakage current	≤ 3.5 mA
Motor protection	Over temperature protected
Life expectance	60,000 hrs at 40 °C / 15 ~ 65 %RH

NOTE : Delta reserves the right to change specifications and other product information without prior notice.

P & Q curves

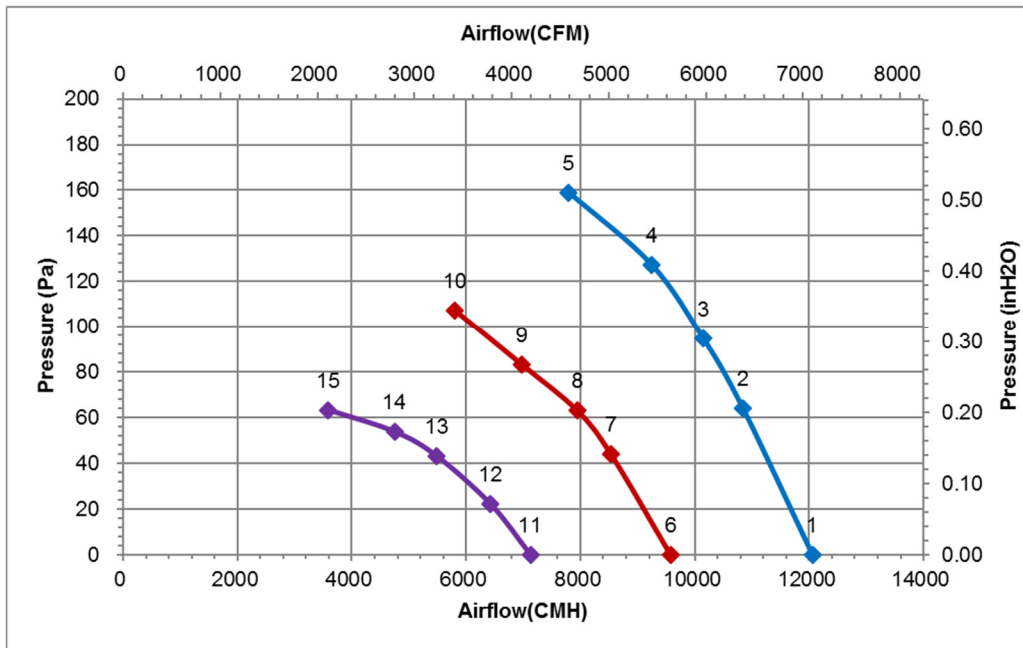

Measure data:

	P [Pa]	Q [CMH]	N [R.P.M.]	P1 [W]	I [A]	Lp [dB(A)]
1	0	12060	1100	497	2.26	71.5
2	64	10839	1100	610	2.73	
3	95	10146	1100	651	2.92	
4	127	9241	1100	694	3.09	
5	159	7792	1100	738	3.31	
6	0	9580	880	258	1.22	66.5
7	44	8532	880	317	1.46	
8	63	7947	880	338	1.55	
9	83	6981	880	362	1.65	
10	107	5800	880	385	1.75	
11	0	7128	660	110	0.61	60.5
12	22	6429	660	134	0.73	
13	43	5480	660	153	0.78	
14	54	4749	660	159	0.80	
15	63	3593	660	173	0.82	

Test condition:

- Input voltage: Nominal voltage
- Temperature : Room temperature
- Humidity : 65%RH
- Measured without Fan-guard.
- Noise (Lp) is measured at a distance of one meter from the fan intake with a sound level meter in anechoic chamber.
- Air performance measurement is compliance with ISO 5801.
- Noise measurement is compliance with ISO 3745 and ISO 13347.

ErP Directive:

	Actual	2015
Over all Eff (%)	51.6	32.8
Eff Grade N	58.9	40
Power (kW)	0.69	
Air flow (CMH)	9241	
Pressure (Pa)	127	
Speed (RPM)	1100	

Dimension drawing

Label :

Label 1

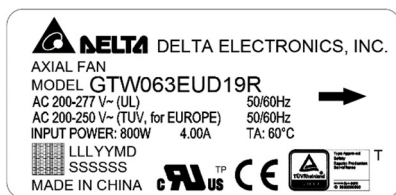

Label 2



Fan :

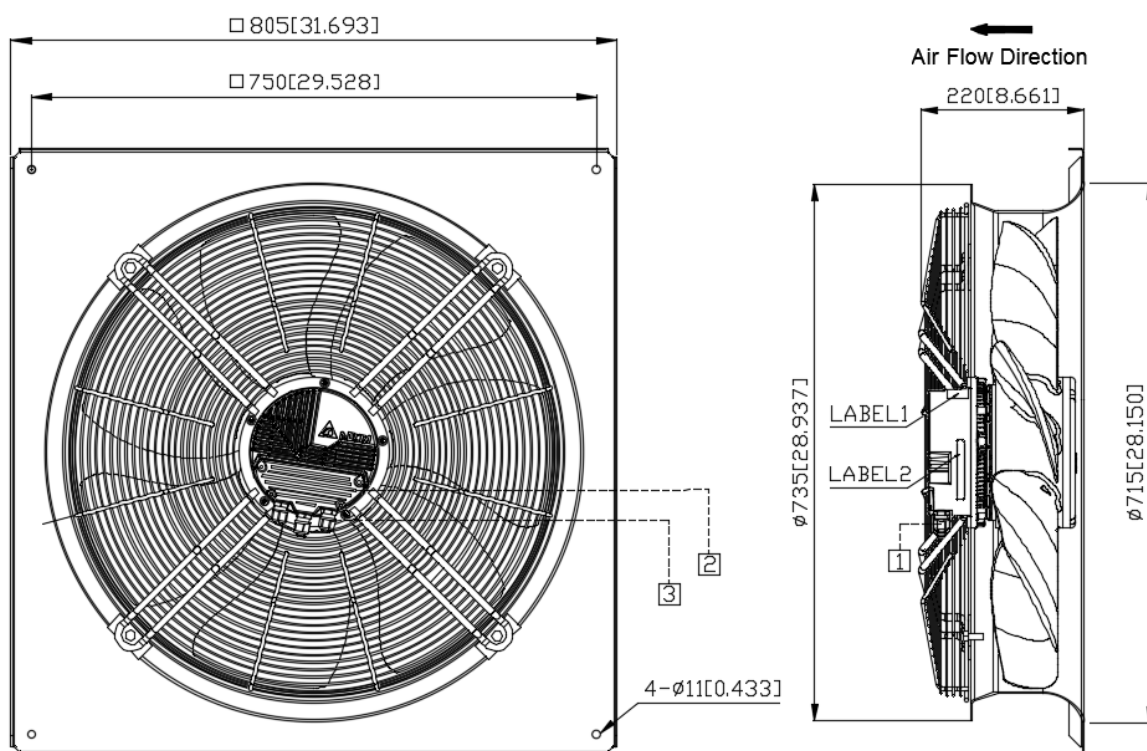

UNIT: mm[INCH]

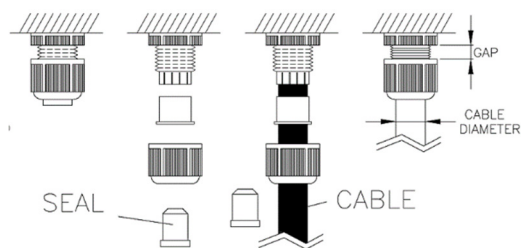

Fig1

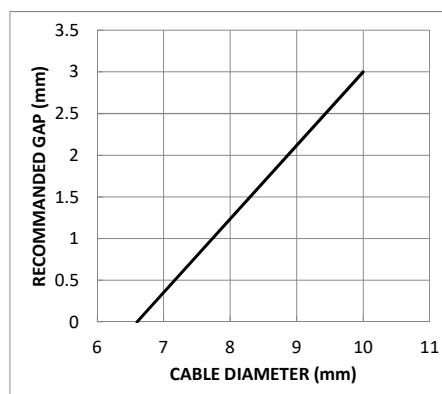
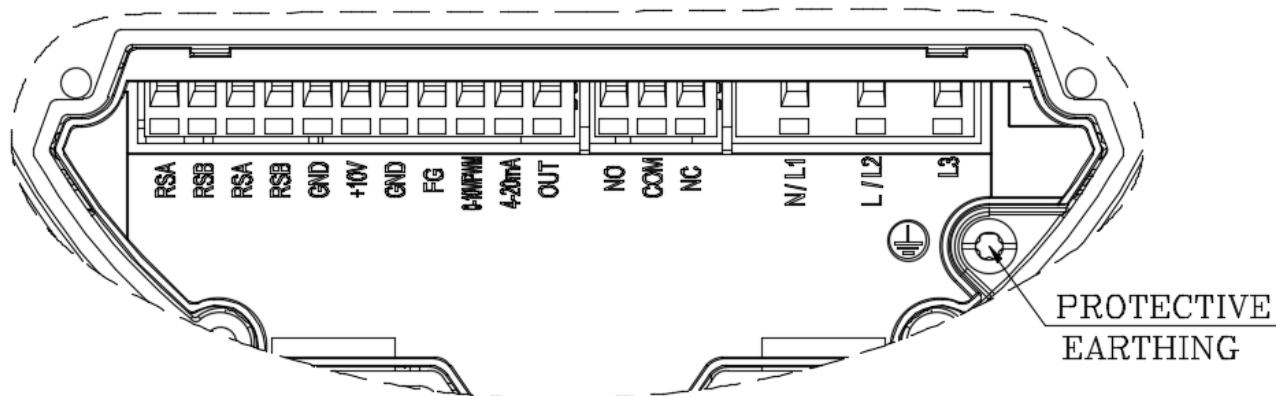

Fig2

Note:

1. Cable Diameter : ϕ 6.6~ ϕ 10.0 mm
2. Open the cover and refer to definition of terminal block.
Screws tighten torque 20 ± 2 Kgf-cm ,when close the cover.
3. Cable sealing nut's gap refer Fig 1 & 2.



Definition of terminal block

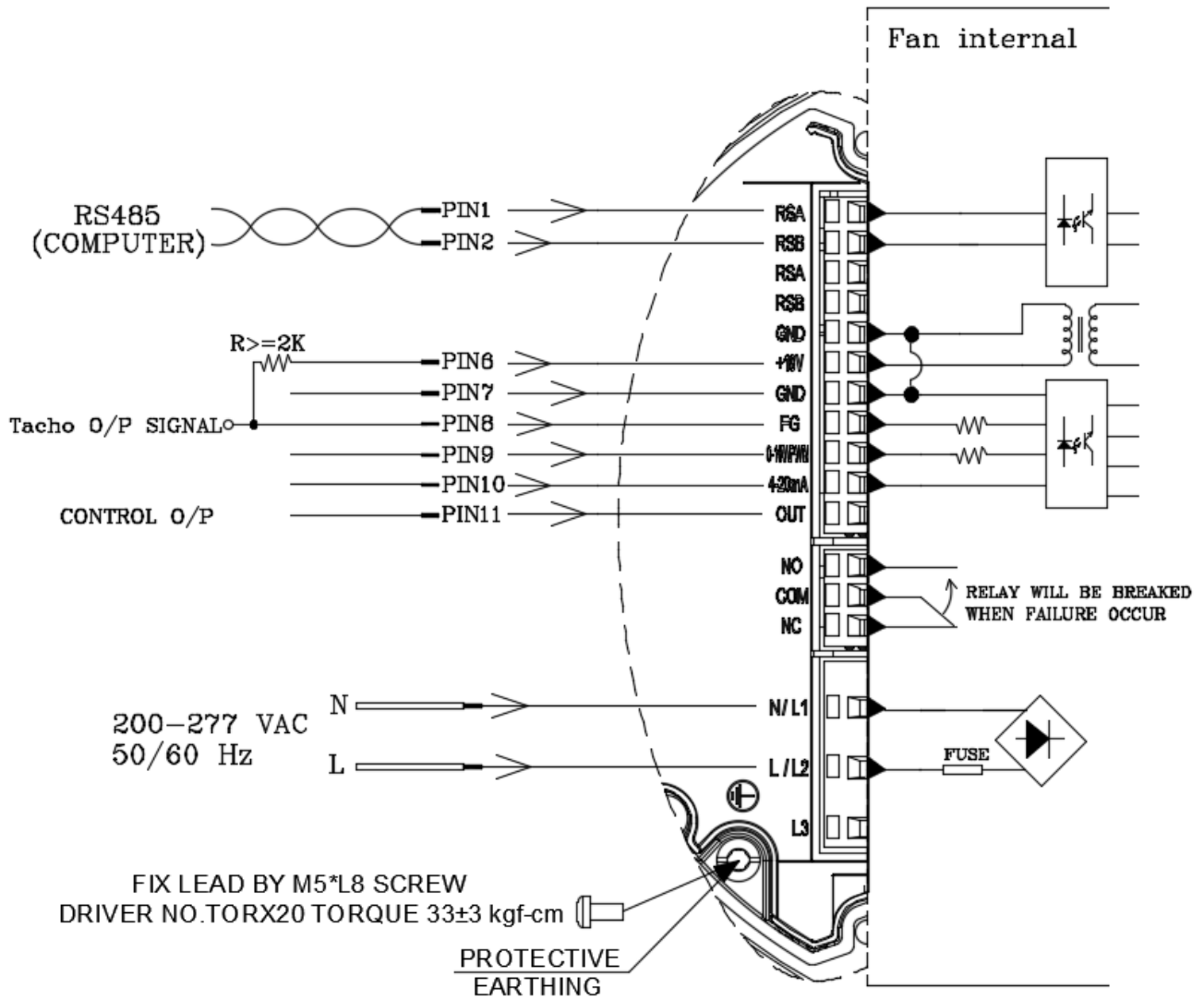

	Text	Functions
Power	N/L1	NEUTRAL/AC main (1~ 200-277VAC)
	L/L2	LINE/AC main (1~ 200-277VAC)
	L3	-----
Status	NO	Alarm relay, open by failure
	COM	Alarm relay, common (2A/250VAC)
	NC	Alarm relay, close by failure
Signal	RSA	RS485-A
	RSB	RS485-B
	RSA	RS485-A
	RSB	RS485-B
	GND	Ground
	+10V	+10V output, MAX 10mA (For external potentiometer)
	GND	Ground
	FG	Frequency generator (FG) signal
	0-10V/PWM	Speed control ,input 0-10VDC
	4-20mA	Speed control ,input 4-20mA
OUT	Control voltage output0-10VDC (For external potentiometer)	

Lead wire connection:

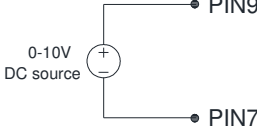
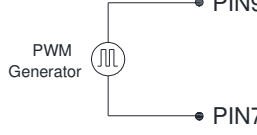
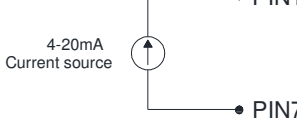

Speed setting	
<p>Full Speed</p> 	<p>Short PIN6& PIN9 Fan will run full speed.</p>
<p>Voltage Control A</p> 	<p>Connector 1-10kΩ variable resistor Between +10VDC with GND and 0-10V/PWM Turn the variable resistor, can change the '0-10V/PWM' voltage (0...10V).</p>
<p>Voltage Control B</p> 	<p>Use voltage source support 0~10VDC voltage DC+ : connector PIN9(+) DC - : connector PIN7(-)</p>
<p>PWM Control</p> 	<p>PWM duty control PWM amplitude is 10VDC(+/-5%) Frequency Range is 100Hz...100kHz -PWM duty higher than 15%, fan start up ° -PWM duty lower than 5%, fan stop °</p>
<p>Current Control</p> 	<p>4~20mA Current Control Open 0-10V/PWM PIN -4.3 mA → Fan Stop -6.0mA → Fan Start up -19.5 mA → Maximum Speed</p>

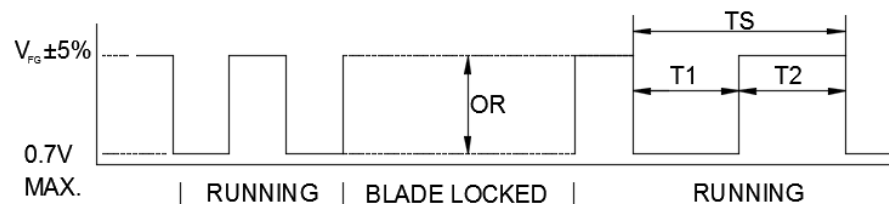
Signal function										
RS485 control function	<p>RS485 control function</p> <ul style="list-style-type: none"> -Select the control mode of speed, fixed speed or fixed PWM duty -Speed and power consumption feedback. -Allow multiple FANs control and status patrol. <p>Cable: A MODBUS over Serial Line Cable must be shielded. At one end of each cable its shield must be connected to protective ground.</p>									
Control O/P	<p>The analog signal level is the derivative of current control level.</p> <table border="1"> <thead> <tr> <th>Current (mA)</th> <th>Control O/P (VDC) (REF)</th> </tr> </thead> <tbody> <tr> <td>4.0</td> <td>0</td> </tr> <tr> <td>19.5</td> <td>9.42</td> </tr> </tbody> </table>	Current (mA)	Control O/P (VDC) (REF)	4.0	0	19.5	9.42			
Current (mA)	Control O/P (VDC) (REF)									
4.0	0									
19.5	9.42									
Voltage/PWM control	<p>The speed comparison will control level</p> <table border="1"> <thead> <tr> <th>Voltage (V)</th> <th>PWM (%)</th> <th>Speed (RPM) (REF)</th> </tr> </thead> <tbody> <tr> <td>0</td> <td>0</td> <td>0</td> </tr> <tr> <td>9.5</td> <td>95</td> <td>1100±5%</td> </tr> </tbody> </table>	Voltage (V)	PWM (%)	Speed (RPM) (REF)	0	0	0	9.5	95	1100±5%
Voltage (V)	PWM (%)	Speed (RPM) (REF)								
0	0	0								
9.5	95	1100±5%								
Current control	<p>The speed comparison will control level</p> <table border="1"> <thead> <tr> <th>Current (mA)</th> <th>Speed (RPM) (REF)</th> </tr> </thead> <tbody> <tr> <td>4.0</td> <td>0</td> </tr> <tr> <td>19.5</td> <td>1100±5%</td> </tr> </tbody> </table>	Current (mA)	Speed (RPM) (REF)	4.0	0	19.5	1100±5%			
Current (mA)	Speed (RPM) (REF)									
4.0	0									
19.5	1100±5%									
Alarm state	<p>NO and COM will OPEN ; NC and COM will CLOSE.</p>									
FG	<p>$V_{CE(sat)} = 0.7V \text{ MAX.}$ $V_{FG} = 30.0V \text{ MAX.}$ $I_C = 5mA \text{ MAX.}$ $R \geq V_{FG} / I_C$</p> <p>Frequency generator waveform</p>  <p style="text-align: center;"> $V_{FG} \pm 5\%$ $0.7V \text{ MAX.}$ </p> <p style="text-align: center;"> RUNNING BLADE LOCKED RUNNING </p> <div style="border: 1px solid black; padding: 5px; width: fit-content; margin: 0 auto;"> <p> $N=R.P.M$ 1 PULSE PER REVOLUTION $TS=60/N(SEC)$ $T1=T2=1/2 TS$ </p> </div>									

Control Voltage VS. RPM Curve

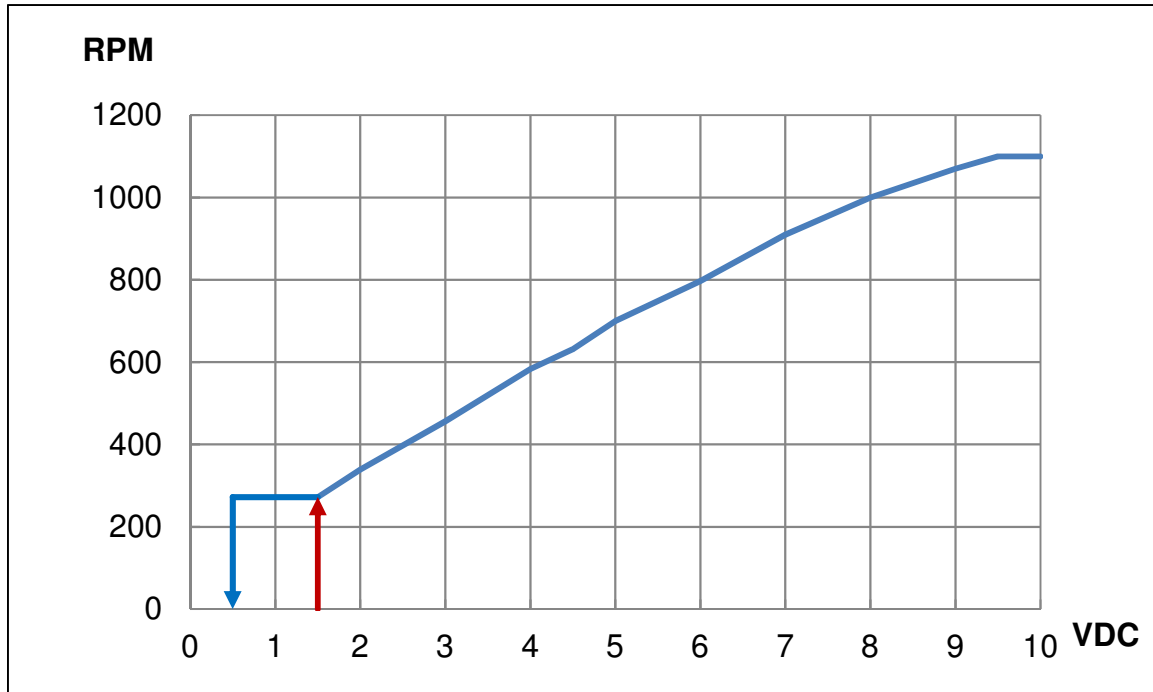

Voltage(VDC) ,PWM duty(%), 4~20mA table

Voltage	0	0.5	1	1.5	2	3	4	5	6	7	8	9	10	VDC
PWM duty	0	5	1	15	20	30	40	50	60	70	80	90	100	%
4~20 mA	4	4.3	5.6	6	7.2	8.8	10.4	12	13.6	15.2	16.8	19	20	mA

Protection Standard

ITEM	Standard
Rain	IEC 60529 IPX4
Dust/sand	IEC 60529 IP5X
Gas corrosion	GR-63-CORE
Salt mist	IEC 60068-2-11

FAN MATERIAL:

- ① Wall-ring: Steel with black powder coating
- ② Guard grille: Steel with black powder coating
- ③ Blades: Plastic (PP)
- ④ Rotor: Steel with black electrodeposition coating
- ⑤ Pillow: Die-cast aluminum
- ⑥ Electronics housing: Die-cast aluminum

